



G L O B A L F O R U M

On Flaring and Venting Reduction
and Natural Gas Utilisation

Oil and Gas Methane Emission Reduction Best Practices

Don Robinson

ICF International on behalf of the
Methane to Markets Partnership

Flaring Reduction Fugitive Emissions Capture are Related

- Flared gas is a major portion of the saleable methane lost from a facility
 - Fugitive and vented methane are the remaining portions
- Recovery of flare gas provides an avenue for capture and use of fugitive and vented emissions
 - Fugitive leak capture is not done if gas is flared
- Capture of fugitive and vented emissions improves economics of flare reduction projects
 - Fugitive and vented emissions often have higher methane and higher heat content
- Most fugitive and vented emissions can be captured for beneficial use

Top Five Fugitive and Vented Emission Sources

- Tank Venting
 - Install Vapor Recovery Units and Micro Turbine Generators
- Pneumatic Instrument Venting
 - Replace High Bleed with Low Bleed or Instrument Air
- Fugitive Emissions
 - Leak Detection and Repair Program with Infrared Technology
- Compressor Seals
 - Replace Centrifugal Compressor Wet Seals with Dry Seals
 - Economic Rod Packing Replacement in Reciprocating Compressors
- Gas Well Venting
 - Reduced Emissions Completions for Gas Wells
 - Smart Automation Plunger Lifts for Liquids Unloading

Tank Venting

- Problem: Gas is vented from low-pressure crude oil and gas condensate storage vessels due to flashing, working, and standing losses
- BMPs: Vapor recovery towers (VRT) and units (VRU) capture tank vapors using compressors



Source: Anadarko, VRT



Source: Hy-Bon Engineering, VRU

Pneumatic Instrument Venting

- Problem: Process controllers, chemical pumps, and glycol pumps often vent pressurized natural gas used for pneumatic actuation



Source: Anadarko, Solar chemical pump

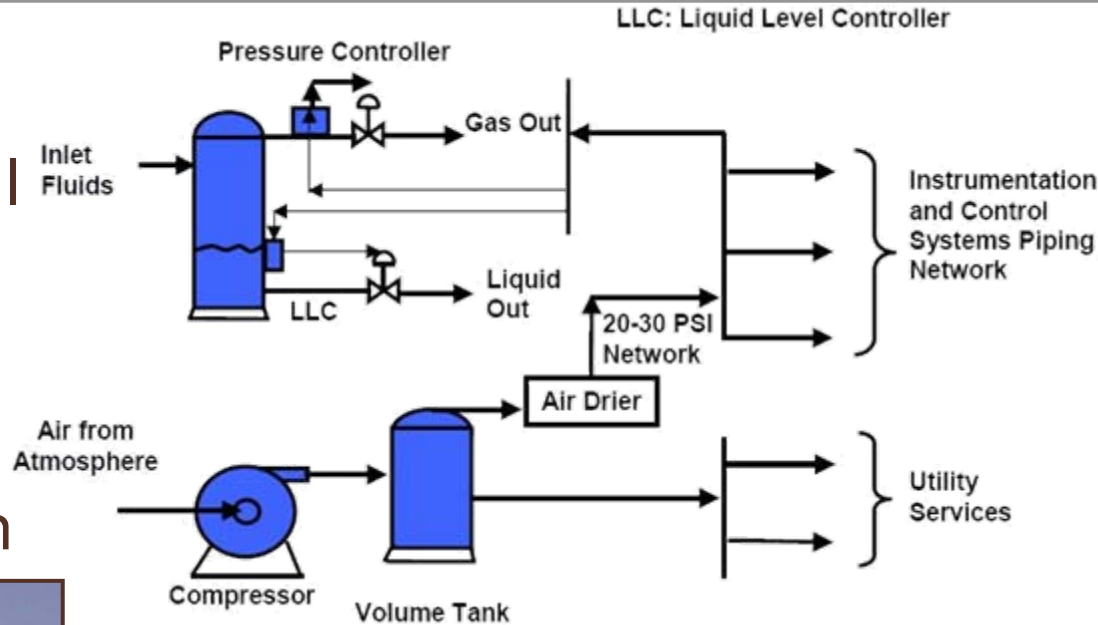

- BMPs:
 - Retrofit high-bleed devices to low-bleed,
 - Replace natural gas with compressed air,
 - Use electric or solar powered pumps

Fugitive Emissions

- Problem: Natural gas is odorless and colorless so leaks from valves, connectors, and open ended lines go unnoticed
- BMPs:
 - Regular leak inspection and repair surveys using leak detection technologies
 - Infrared remote leak detection technologies



Source: Leak Surveys, Hand-held camera

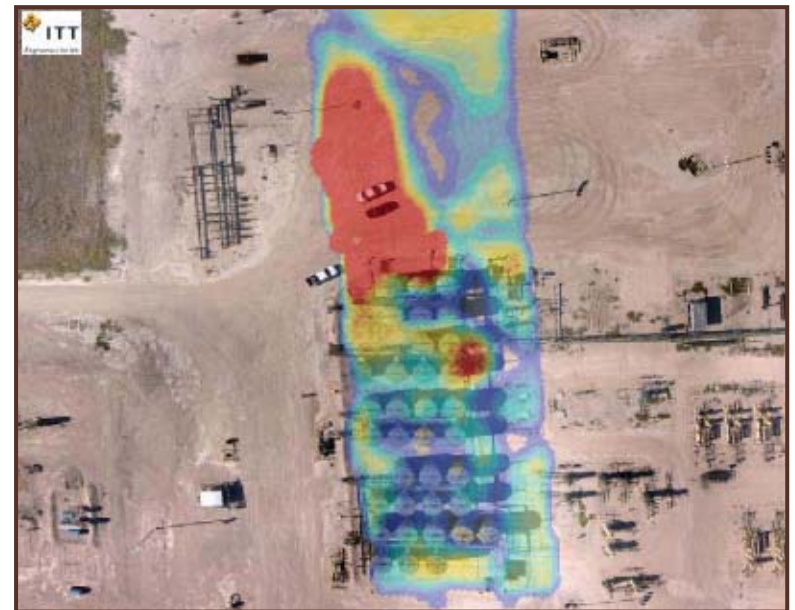

Source: ANGEL, Aerial image

Fugitive Emissions Measurement

- Verification of emission reductions and project scoping requires emissions measurement
 - High volume sampler measures emissions up to 14 m³/hour
 - Rotameter measures flow rate of vent stacks
 - Calibrated bags measure vent emissions by timing inflation



High volume sampler in use

Compressor Methane Losses

- Problem: Compressor seals are designed to leak gas, shutdown practices vent large volumes of gas
- BMPs:
 - Economic replacement of rod packing,
 - Replace wet seals with dry seals,
 - Route blowdown gas to fuel



Source: CECO, Rod packing

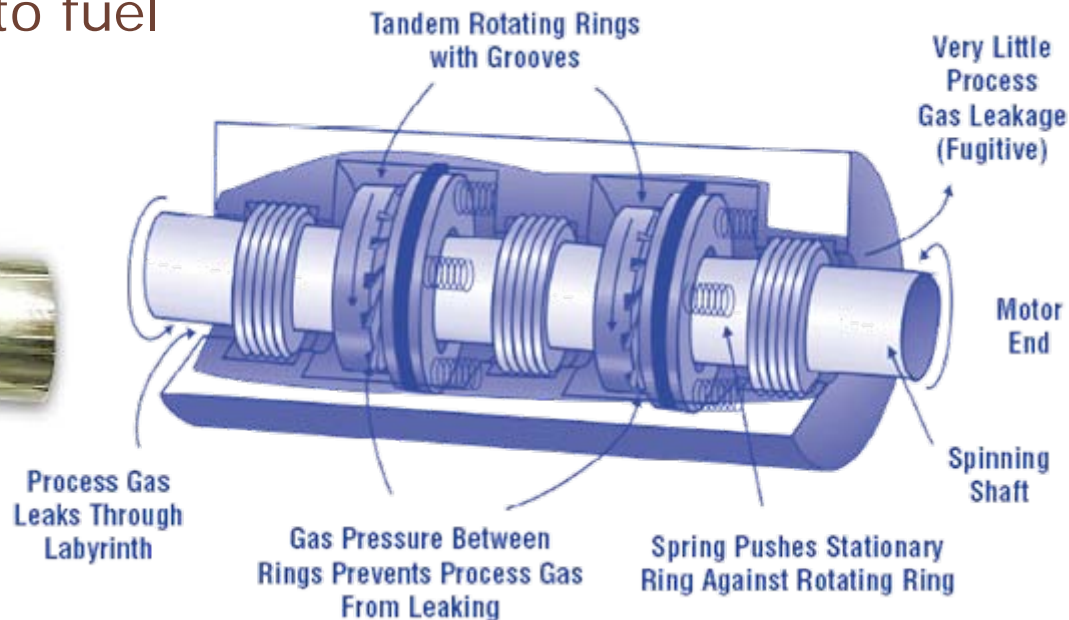

Gas Well Venting

- Problem: Well completion and liquids unloading vent large volumes of gas
- BMPs:
 - Recover completion gas with portable separation and treatment equipment
 - Smart automation plunger lift reduces operational venting



Source: Williams, Completion skid

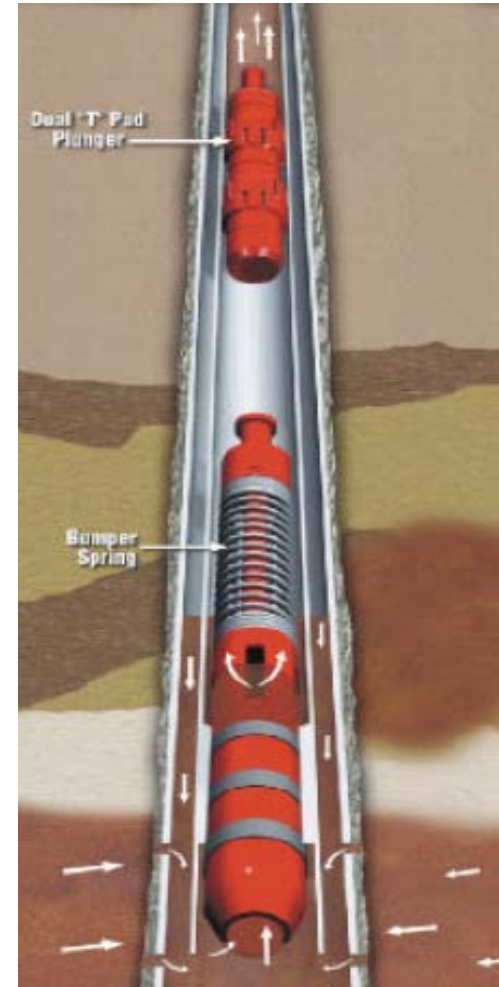

Source: Weatherford, Plunger lift diagram

Methane to Markets Best Practices Technical Documents

- Methane to Markets has documents that address BMPs for these sources and more
- Over 80 technical documents available in Chinese, Russian, Spanish, and English online at: epa.gov/gasstar

天然气工业中减少气动装置排放甲烷的方案

OPTIONS
FROM PNEUMATIC

1 内容提要

压缩天然气驱动的气动装置器。据估计，生产环节中每年从立方英尺、输送环节有 140 亿立之一。使用低排气装置更换高排气排放量能取得很好的经济效益。天然气 STAR 合作伙伴通过量。合作伙伴发现，绝大多数改回收。迄今为止，合作伙伴通过亿立方英尺的甲烷气体，也即节器的结构、使用条件和具体工作

Опыт
примене

От партнеров програм

DIRECTED INSPECTION
COMPRESSOR STATIO
ЦЕЛЕНАПРАВЛЕННОЕ
ОБСЛУЖИВАНИЕ КОМ

Аннотация

Общая протяженность газопроводов США г
компрессорные станции являются крупней
фут.² (1,43 млн. м²) ежегодных утечек из ко
соединений, муфт и обвязки. Данные, полу
95 % регистрируемой эмиссии метана на 20
станций.

Программа целенаправленного обследован
является надежным, эффективным методо
устранению утечек и снижению эмиссии ме
выявления мест и объемов утечек. Технологи
используются для ремонта узлов с нарушен

Lecciones
Aprendidas

De los participantes de Natur

REDUCCIÓN DE EMISIONES DE
EMPAQUETADURA DEL VASTAGO
Methane Emissions from Comp

Resumen gerencial

En los Estados Unidos existen más de 20,000 compresores de
uno con un promedio de cuatro cilindros, lo cual representa ap
véstagos de pistón en servicio. Estos sistemas contribuyen con
atmósfera, lo que representa una de las más grandes fuentes de

Lessons
Learned

From Natural Gas STAR Partners

INSTALLING VAPOR RECOVERY UNITS ON CRUDE OIL
STORAGE TANKS



Methane Saving Project Experiences

- Methane to Markets Participants are currently using technologies to recover valuable vented and fugitive methane
- Selected technology presentations for this section:
 - Micro-turbines and other uses for low-pressure gas (BP experience)
 - Latest technology to identify, measure and recover tank emissions (Hy-Bon experience)
 - Advanced well completions and infrared cameras for leak detection (Marathon experience)
 - Infrared methane emissions imaging (FLIR experience)

Contact Information

- Don Robinson
ICF International on behalf of
Methane to Markets, and
Natural Gas STAR International
(703) 218-2512
drobinson@icfi.com



methanetomarkets.org

epa.gov/gasstar